

Fig. 1-14. Shaper tools for cutting cast iron. A. Roughing tool. B. High lead angle roughing tool. C. Cast-iron finishing tool.

Ch. 1 SHAPER CONSTRUCTION AND SHAPER TOOLS 17

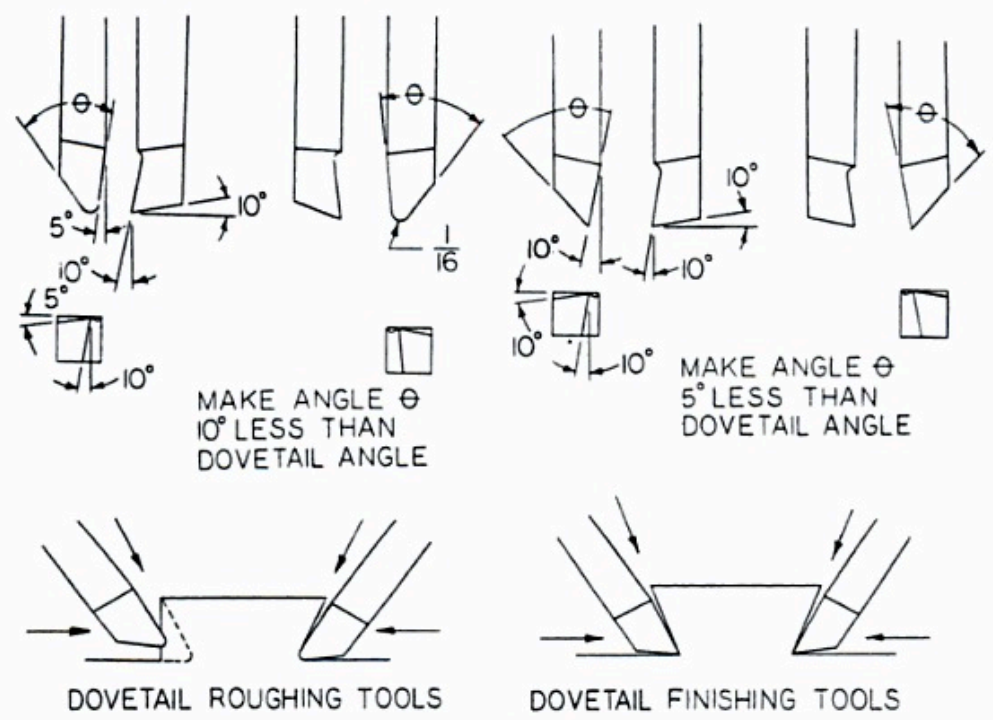

Fig. 1-16. Dovetail roughing tools (left) and finishing tools (right).

for cutting either cast iron or steel. At C the tool illustrated is called a keyseating tool, which is used to machine slots and keyseats in either cast iron or steel parts. Cutting tools for rough- and finish-shaping dovetails are shown in Fig. 1-16. These tools sometimes have a small radius at the nose instead of a sharp nose as shown in this illustration. The 5-degree angles on the sides of the roughing tools and the 10-degree angles on the sides of the finishing tools must sometimes be reduced if the angle of the dovetail being cut becomes small. These angles are very satisfactory for 60-degree dovetail angles.